

N10HD Series_Hardware Design

GNSS Module Series

Version: V1.0

Date: 2022-04-07

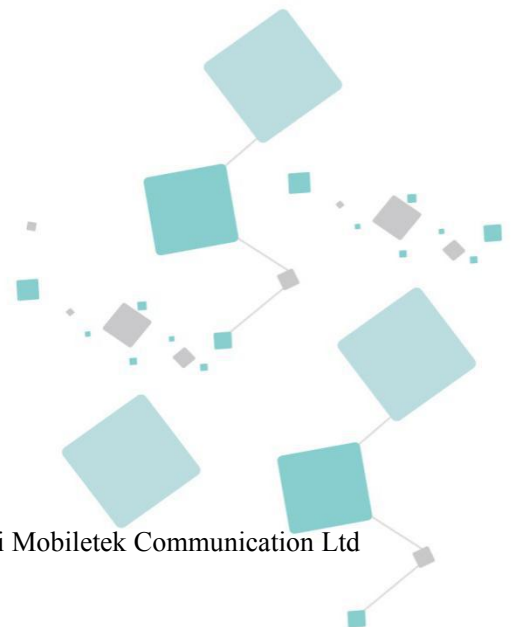

Notice

Some features of the product and its accessories described herein rely on the software installed, capacities and settings of local network, and therefore may not be activated or may be limited by local network operators or network service providers. Thus, the descriptions herein may not exactly match the product or its accessories which you purchase. Shanghai Mobiletek Communication Ltd reserves the right to change or modify any information or specifications contained in this manual without prior notice and without any liability.

Copyright

This document contains proprietary technical information which is the property of Shanghai Mobiletek Communication Ltd. copying of this document and giving it to others and the using or communication of the contents thereof, are forbidden without express authority. Offenders are liable to the payment of damages. All rights reserved in the event of grant of patent or the registration of a utility model or design. All specification supplied herein are subject to change without notice at any time.

DISCLAIMER

ALL CONTENTS OF THIS MANUAL ARE PROVIDED "AS IS". EXCEPT AS REQUIRED BY APPLICABLE LAWS, NO WARRANTIES OF ANY KIND, EITHER EXPRESS OR IMPLIED, INCLUDING BUT NOT LIMITED TO, THE IMPLIED WARRANTIES OF MERCHANTABILITY AND FITNESS FOR A PARTICULAR PURPOSE, ARE MADE IN RELATION TO THE ACCURACY, RELIABILITY OR CONTENTS OF THIS MANUAL. TO THE MAXIMUM EXTENT PERMITTED BY APPLICABLE LAW, IN NO EVENT SHALL SHANGHAI MOBILETEK COMMUNICATION LTD BE LIABLE FOR ANY SPECIAL, INCIDENTAL, INDIRECT, OR CONSEQUENTIAL DAMAGES, OR LOSS OF PROFITS, BUSINESS, REVENUE, DATA, GOODWILL SAVINGS OR ANTICIPATED SAVINGS REGARDLESS OF WHETHER SUCH LOSSES ARE FORSEEABLE OR NOT.

Version History

Date	Version	Modify records	Author
2021-04-06	V1.0	Origin	liuwenhong

CONTENT

FIGURES.....	5
TABLES.....	6
1. INTRODUCTION.....	7
2. N10HD SERIES OVERVIEW.....	7
2.1 N10HD SERIES FUNCTIONAL DIAGRAM.....	8
2.2 GNSS PERFORMANCE.....	9
3. PACKAGE INFORMATION.....	11
3.1 PIN OUT DIAGRAM.....	11
3.2 PIN DESCRIPTION.....	11
3.3 PACKAGE DIMENSIONS.....	12
3.4 N10HD SERIES RECOMMENDED PCB DECAL.....	14
4. APPLICATION INTERFACE.....	15
4.1 POWER MANAGEMENT.....	15
4.1.1 Power Input.....	15
4.1.2 Starting N10HD Series.....	15
4.1.3 Verification of N10HD Series Start.....	15
4.1.4 Power Saving Modes.....	15
4.1.6 VCC_RF.....	17
4.1.7 ANTON.....	17
4.2 UART INTERFACE.....	18
4.3 RESET INPUT.....	18
4.4 PPS OUTPUT.....	18
4.5 AGPS AND DGPS.....	19
4.5.1 EPO.....	19
4.5.2 EASY™ MODE.....	20
4.5.3 DGPS.....	20
4.6 GNSS ANTENNA.....	21
4.6.1 Antenna Interface.....	21
4.6.2 Antenna Choice and RF Design Consideration.....	21
5. ELECTRICAL RELIABILITY AND RADIO CHARACTERISTICS.....	26
5.1 ABSOLUTE MAXIMUM RATINGS.....	26
5.2 RECOMMENDED OPERATING CONDITIONS.....	26
5.3 ELECTRO-STATIC DISCHARGE.....	27
6. MANUFACTURING.....	29
6.1 TOP AND BOTTOM VIEW OF N10HD SERIES.....	29
6.2 PRODUCT LABELING.....	29
6.3 ASSEMBLY AND SOLDERING.....	30

6.4 MOISTURE SENSITIVITY.....	31
6.5 ESD HANDLING PRECAUTIONS.....	32
6.6 SHIPMENT.....	33
7. REFERENCE DESIGN.....	34
8. SAFETY INFORMATION.....	35
APPENDIX.....	36
<i>Related Documents</i>	36
<i>Terms and Abbreviations</i>	36

FIGURES

FIGURE 2-1 N10HD SERIES FUNCTIONAL DIAGRAM.....	9
FIGURE 3-1 N10HD SERIES PIN OUT DIAGRAM (TOP VIEW).....	11
FIGURE 3-2 N10HD SERIES MECHANICAL DIMENSIONS (UNIT: MM).....	13
FIGURE 3-3 RECOMMENDED PCB DECAL (TOP VIEW) (UNIT: MM).....	14
FIGURE 4-1 PERIODIC MODE.....	17
FIGURE 4-2 PPS APPLICATION CIRCUIT.....	19
FIGURE 4-3 N10HD SERIES PASSIVE ANTENNA DESIGN.....	23
FIGURE 4-4 N10HD SERIES PASSIVE ANTENNA DESIGN(WITH EXTERNAL SAW).....	23
FIGURE 4-5 N10HD SERIES PASSIVE ANTENNA DESIGN(WITH EXTERNAL LNA AND SAW).....	24
FIGURE 4-6 N10HD SERIES ACTIVE ANTENNA DESIGN.....	24
FIGURE 4-7 N10HDHD SERIES ACTIVE ANTENNA DESIGN FOR LOW POWER CONSUMPTION.....	25
FIGURE 6-1 TOP AND BOTTOM VIEW OF N10HD SERIES.....	29
FIGURE 6-2 LABEL OF N10HD SERIES.....	29
FIGURE 6-3 THE RAMP-SOAK-SPIKE REFLOW PROFILE OF N10HD SERIES.....	30
FIGURE 7-1 APPLICATION SCHEMATICS.....	34

TABLES

TABLE 2-1 GNSS PERFORMANCE.....	9
TABLE 3-1 PIN DESCRIPTION.....	11
TABLE 4-1 POWER SUPPLY AND CLOCK STATE ACCORDING TO OPERATION MODE.....	16
TABLE 4-2 ANTON STATUS.....	18
TABLE 4-3 ANTENNA SPECIFICATIONS.....	22
TABLE 5-1 ABSOLUTE MAXIMUM RATING.....	26
TABLE 5-2 N10HD SERIES OPERATING CONDITIONS.....	26
TABLE 5-3 N10HD SERIES STANDARD IO FEATURE.....	27
TABLE 5-4 THE ESD CHARACTERISTICS(TEMPERATURE:25°C,HUMIDITY:45%).....	27
TABLE 6-1 DESCRIPTION OF MODULE LABEL.....	30
TABLE 6-2 MOISTURE CLASSIFICATION LEVEL AND FLOOR LIFE.....	31

1. Introduction

This document describes the hardware interface of the module N10HD which can be used as a GNSS or A-GNSS receiver. As a wide range of applications can be integrated in N10HD, all functional components of N10HD are described in great detail.

2. N10HD Series Overview

N10HD series is a GNSS or A-GPS receiver. With built-in LNA, N10HD series don't need for external LNA. N10HD series can track as low as -162dBm signal even without assistance network (up to 45dB C/N of SVs in open sky).

N10HD series has excellent low power consumption characteristic. N10HD series supports various location and navigation applications, including autonomous GPS/Galileo/Glonass/BD2/QZSS/SBAS (WAAS, EGNOS, GAGAN, MSAS), DGPS and A-GPS.

Key Features

- Small footprint: 10 .1x 9.7 x 2.5mm, 18-pin LCC package
- 12 multi-tone active interference cancellers and jamming elimination
- Indoor and outdoor multi-path detection and compensation
- Advanced software features
 1. EASY™ self-generated orbit prediction for instant positioning fix
 2. AGPS Support for Fast TTFF (EPO orbit prediction)
 3. Supports logger function
 4. Supports active interference cancellation (AIC)
- Pulse-per-second (PPS) GNSS time reference
 - Adjustable duty cycle

Typical accuracy: $\pm 10\text{ns}$

- Interface

UART0 (Default)

- Operating temperature: $-40 \sim +85^{\circ}\text{C}$
- Accuracy $< 2.5\text{m CEP}$
- ROHS compliant

The module provides complete signal processing from antenna input to host port in either NMEA messages. The module requires 3.0V~4.3V power supply. The host port is configurable to UART. Host data and I/O signal levels are 2.85V CMOS compatible.

2.1 N10HD Series Functional Diagram

The following figure shows a functional diagram of the N10HD series and illustrates the mainly functional parts:

- The GNSS chip
- SAW filter
- LNA
- The antenna interface
- The communication interface
- The control signals

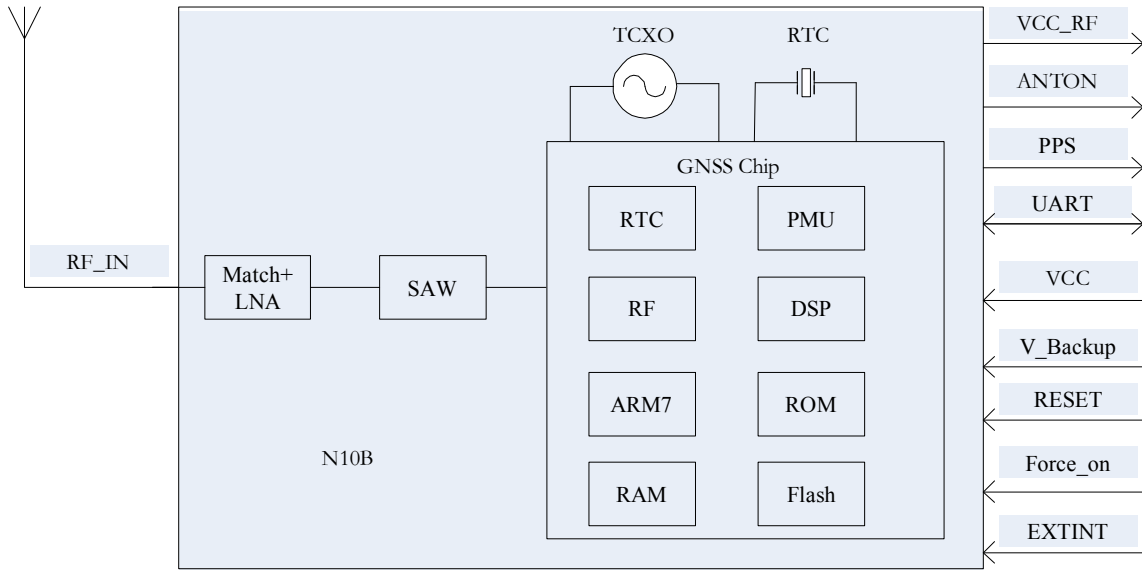

Figure 2-1 N10HD series functional diagram

2.2 GNSS Performance

Table 2-1 GNSS performance

Parameter	Description	Performance			
		Min	Type	Max	Unit
Horizontal Position Accuracy ⁽¹⁾	Autonomous		<3		m
Velocity Accuracy ⁽²⁾	Without Aid		0.1		m/s
Timing Accuracy			20		ns
Dynamic Performance	Maximum Altitude			> 18000	m
	Maximum Velocity			> 515	m/s
	Maximum Acceleration			> 4	G
GPS+BD2 Time To First Fix ⁽³⁾	Hot start		<1		s
	Warm start		28		s
	Cold start		30		s
A-GNSS TTFF	Hot start		<1		s
	Warm start		TBD		s

	Cold start		TBD		s
GPS+BD2 Sensitivity ⁽⁴⁾	Autonomous acquisition(cold start)		-146		dBm
	Re-acquisition		-155		dBm
	Tracking		-158		dBm
Receiver	Channels		88		
	Update rate		1	5	Hz
GPS Power consumption ⁽⁴⁾	Acquisition		20		mA
	Continuous tracking		18		mA
	Sleep current		3		mA
	Backup current		16		uA

(1) 50% 24hr static, -130dBm

(2) 50% at 30m/s

(3) More than 6 satellites, all satellites strength -130dBm , all time statistics for the test 10 times average (when PDOP 5, positioning error is less than 10m)

(4) Single Power supply 3.3V under GPS+BD2 signal@ -130dBm /External LNA noise coefficient is 0.8.

3. Package Information

3.1 Pin Out Diagram

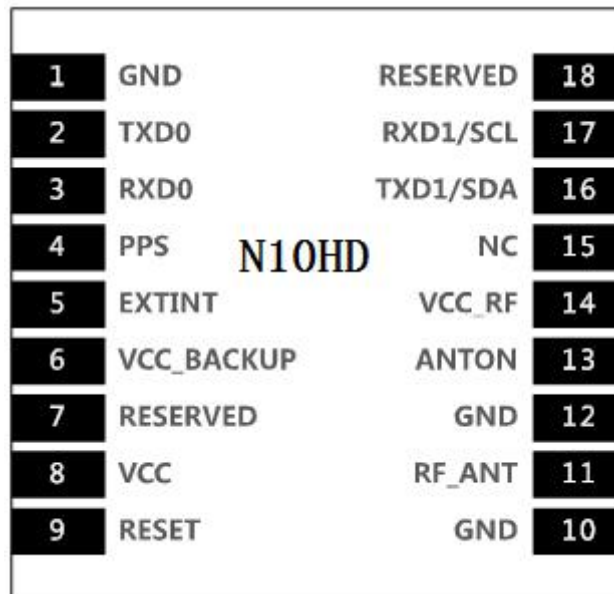

Figure 3-1 N10HD series pin out diagram (Top view)

3.2 Pin Description

Table 3-1 Pin description

Pin name	Pin number	I/O	Description	Comment
Power supply				
VCC	8	I	Main power input, Typical: 3.3V. Recommend LDO as VCC, ripple rejection: >60dB@1kHz	Add a 4.7uF capacitor to this pin for decoupling.
ANTON	13	O	3.3V power output supply for active antenna or external LNA control pin for power save	If unused, keep open.
VCC_RF	14	O	Power supply for active antenna or external LNA	If unused, keep open.

VCC_BACKUP	6	I	The backup battery input power supply for RTC 2.0V~3.6V, Typical 3.0V	If unused, keep open.
GND	1 10 12		Ground	
Host port interface				
TXD0	2	O	Serial data output of NMEA	
RXD0	3	I	Serial data input for firmware update	
TXD1/SDA	16	I/O	Serial output as RTCM	I2C requires a special version, please contact MOBILETEK
RXD1/SCL	17	I	Serial input as RTCM	
GPIOs				
PPS	4	O	1PPS Time Mark Output 3.3V CMOS Level ,timing pulse related to receiver time	If unused, keep open.
RESET	9	I	Reset input, active low, default pull-up	If unused, keep open.
EXTINT(NC)	5	I	This interrupt source could act as wake up event during power saving mode.	If unused, keep open. Not supported by N10HDB-M, N10HDB-H please keep open.
RESERVED (FORCE_ON)	18	I	Logic high will Force module to be waked up from backup mode	Keep this pin open or pulled low before Entering into backup mode. If unused, keep open
RF interface				
RF_ANT	11	I	GNSS antenna port	Impedence must be controlled to 50Ω.
Other interface				
RESERVED/ NC	7 15		Not Connected	

3.3 Package Dimensions

Following figure shows the Mechanical dimensions of N10HD series (top view, side view and bottom

view).

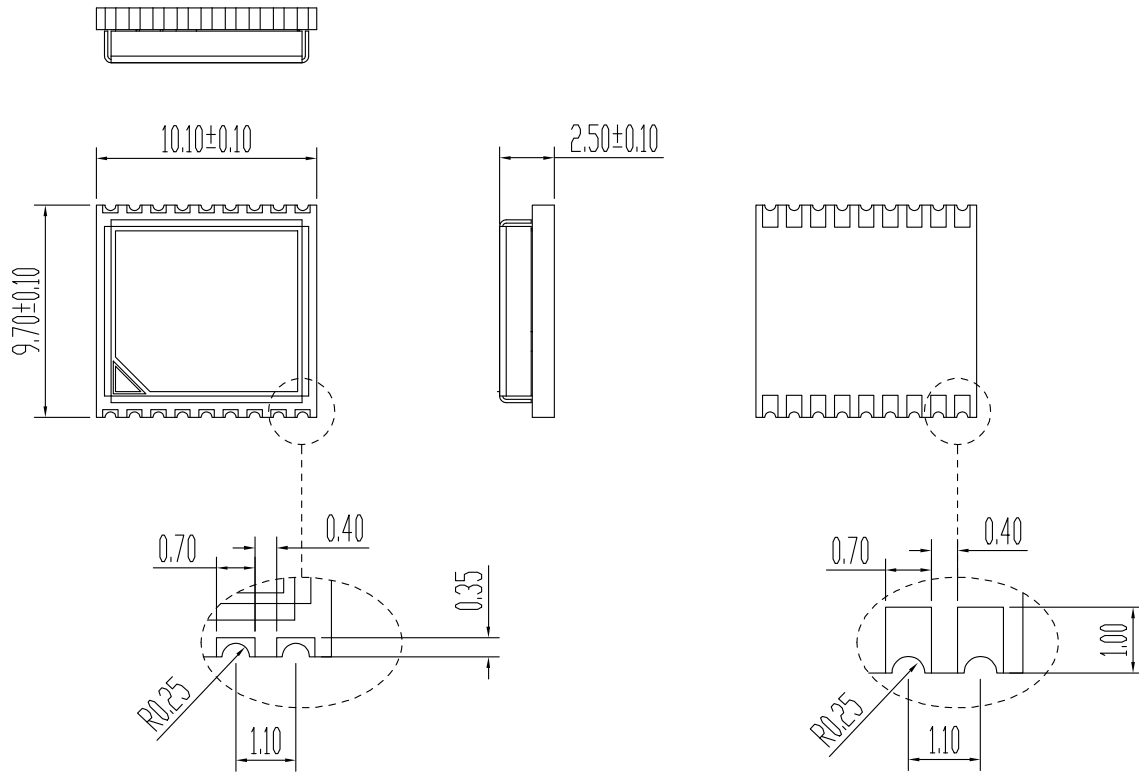

Figure 3-2 N10HD series mechanical dimensions (Unit: mm)

3.4 N10HD Series Recommended PCB Decal

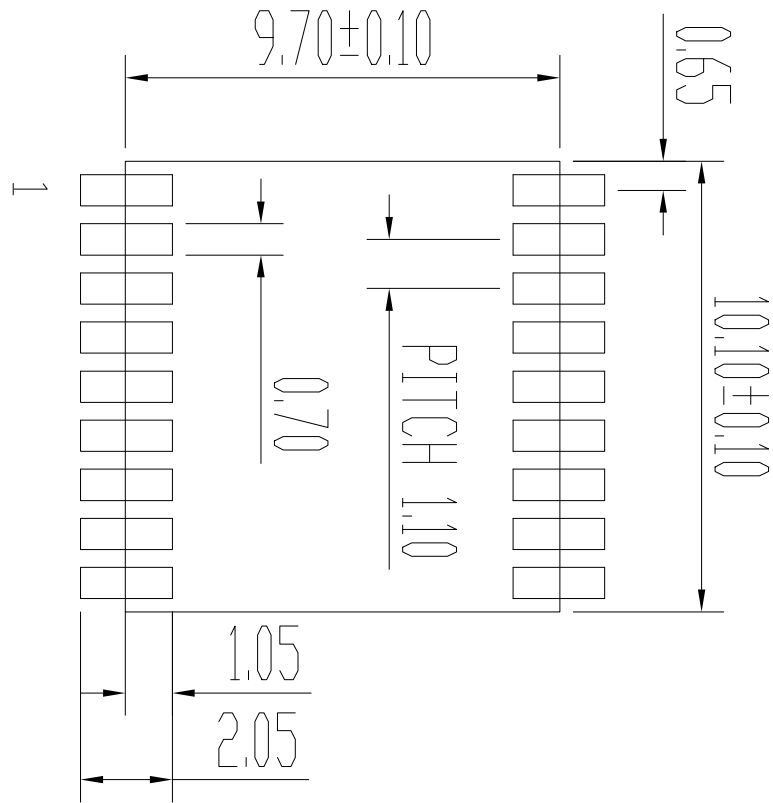

Figure 3-3 Recommended PCB decal (top view) (Unit: mm)

4. Application Interface

4.1 Power Management

4.1.1 Power Input

The power supply range of N10HD series is from 3.0V to 3.6V. The power supply should be able to provide sufficient current up to 100mA.

The power supply range of VCC_BACKUP is from 2.0V to 3.6V, typical 3.0V, suggesting customer keep the VCC_BACKUP supply active all the time, module will perform a quick start every time it is power-on.

Note: IF VCC_BACKUP power was not reserved, the GNSS module will perform a lengthy cold start every time it is powered-on because previous satellite information is not retained and needs to be re-transmitted

4.1.2 Starting N10HD Series

When power is first applied, N10HD series goes into working mode.

4.1.3 Verification of N10HD Series Start

System activity indication depends upon the chosen serial interface: When it is activated, N10HD series will output messages at the selected UART speed and message types.

4.1.4 Power Saving Modes

N10HD series supports operating modes for reduced average power consumption like standby mode, backup mode, and periodic mode.

- **Standby mode:** In this mode the receiver stays at full on power state. When this mode that can be wake up by the host sends the command through the communication interface.
- **Backup mode:** In this mode, the N10HD series must be supplied by the VCC_BACKUP pin and the VCC power should be cut off.
- **Periodic mode:** In this mode the N10HD series enters tracking and sleep or Backup mode according to the interval configured.

Table 4-1 Power supply and clock state according to operation mode

Mode	VCC	VCC_BACKUP	Internal LDO	Main clock	RTC clock
Full on	on	on	on	on	on
Sleep	on	on	on	off	on
Backup	off	on	off	off	on

4.1.5.1 Full on Mode

The module will enter full on mode after first power up with factory configuration settings. Power consumption will vary depending on the amount of satellite acquisitions and number of satellites in track.

4.1.5.2 Standby Mode

Standby mode means a low quiescent (340uA type.) power state, non-volatile RTC, and backup RAM block is powered on. Other internal blocks like digital baseband and RF are internally powered off. The power supply input VCC shall be kept active all the time, even during sleep mode.

4.1.5.3 Backup Mode

This connects to the backup power of the module. Power source (such as battery or cap) connected to VCC_BACKUP pin will help the chipset in keeping its internal RTC running when the VCC power

source is turned off. The voltage should be kept between 2.0~3.6V, Typical 3.0V. It is recommended to power VCC_BACKUP through a battery, which can ensure the module EASY™ and improves TTF after next restart.

The VCC_BACKUP power should be kept active all the time, the module will perform a quick start every time it is power-on.

4.1.5.4 Periodic Mode

In this mode the N10HD series enters tracking and sleep or Backup mode according to the interval configured by users in the commands.

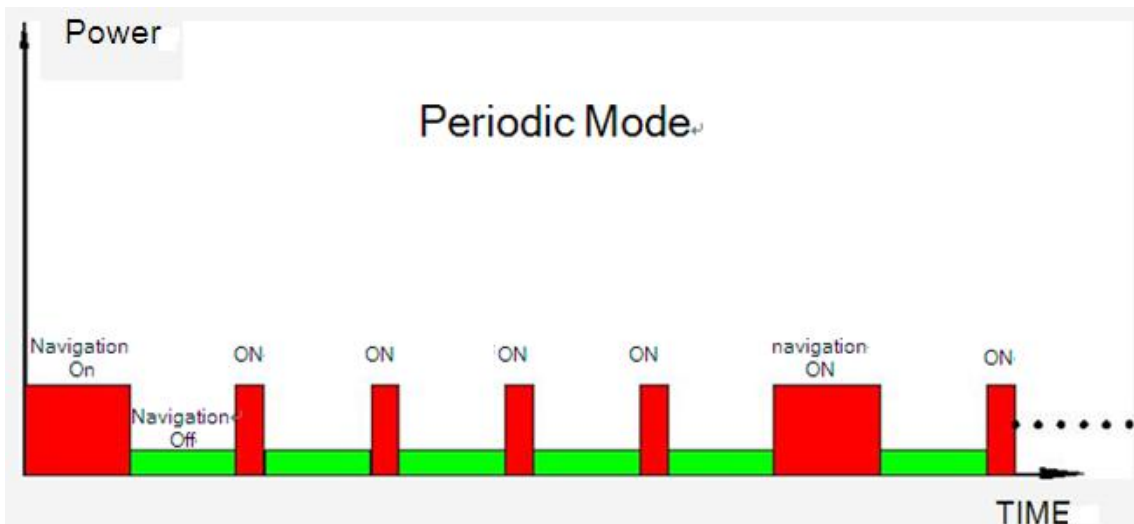

Figure 4-1 Periodic mode

4.1.6 VCC_RF

Power supply for active antenna or external LNA, the power domain is VCC.

4.1.7 ANTON

2.8V power output for active antenna or external LNA control pin for power save. See the following table for details.

Table 4-2 ANTON status

Mode	ANTON
Full on	3.3V power output
Sleep	no power output
Backup	no power output

4.2 UART Interface

N10HD series includes two UART (UART0 and UART1) interface for serial communication. The UART0 is as NMEA output and PMTK command input. The receiver (RXD0) and transmitter (TXD0) side of every port contains a 16-byte FIFO and has 256 bytes URAM. UART can provide the developers signal or message outputs. The baud rates are selectable and ranging from 9.6 to 115.2kbps through PMTK commands. UART1 is as RTCM input.

4.3 RESET Input

The RESET pin (active low) is used to reset the system, normally external control of RESET is not necessary. The signal can be left floating, if not used.

When RESET signal is used, it will force volatile RAM data loss. Note that Non-Volatile backup RAM content is not cleared and thus fast TTFB is possible. The input has internal pull up.

4.4 PPS Output

The PPS pin outputs one pulse-per-second (1PPS) pulse signal for precise timing purposes. The PPS signal can be provided through designated output pin for many external applications. This pulse is not only limited to be active every second but also allowed to set the required duration, frequency, and active high/low by programming user-defined settings.

The following figure is the typical application of the PPS function.

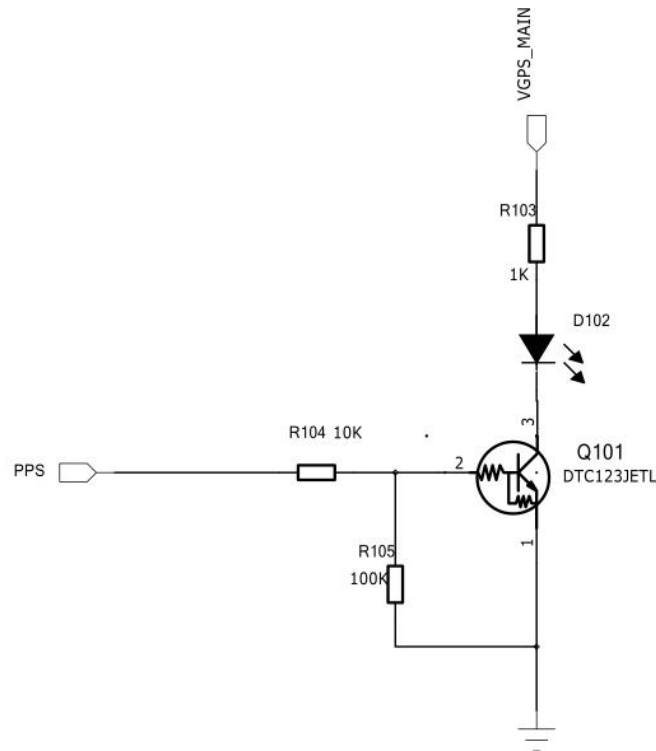

Figure 4-2 PPS application circuit

4.5 AGPS and DGPS

A-GPS is the meaning of Assisted GPS, which is a system that can improve the startup performance and time-to-first-fix (TTFF) of a GPS satellite-based positioning under certain conditions. N10HD series module supports EPO file, EASY™ mode.

4.5.1 EPO

The N10HD series supports the EPO (Extended Prediction Orbit) data service. The EPO data service is supporting 7/14/30-day orbit predictions to customers. It needs occasional download from EPO server. Supply of aiding information like ephemeris, almanac, rough last position and time and satellite status and an optional time synchronization signal will reduce time to first fix significantly and improve the acquisition sensitivity.

The user should update the EPO files from the EPO server daily through the internet. Then the EPO data should send to the N10HD series by the HOST side. N10HD series has the short cold TTFF and

warm TTFF, when the A-GPS is used.

Note: For more information about EPO, please contact MOBILETEK sales. Users can refer to document [2] for more information

4.5.2 EASY™ MODE

EASY™ is the abbreviation of Embedded Assist System, it works as embedded firmware which accelerates TTFF by predicting satellite navigation messages from received ephemeris.

No additional computing interval for EASY™ task. EASY™ is efficiently scheduled and computed in free time of every second after GNSS navigation solution.

EASY™ function is conceptually designed to automatically engage for predicting after first receiving the broadcast ephemeris. After a while (generally tens of seconds), 3-day extensions will be completely generated then all EASY™ functions will be maintained at a sleep condition. EASY™ assistance is going to be engaged when the GNSS requests in new TTFF condition or re-generates again with another new received ephemeris. Meanwhile, TTFF will be benefited by EASY™ assistance.

Note: EASY™ function is default open and can be closed by PMTK command.

4.5.3 DGPS

SBAS is the abbreviation of Satellite Based Augmentation System. The SBAS concept is based on the transmission of differential corrections and integrity messages for navigation satellites that are within sight of a network of reference stations deployed across an entire continent. SBAS messages are broadcast via geostationary satellites able to cover vast areas.

Several countries have implemented their own satellite-based augmentation system. Europe has the European Geostationary Navigation Overlay Service (EGNOS) which covers Western Europe and beyond. The USA has its Wide Area Augmentation System (WAAS). Japan is covered by its Multi-functional Satellite Augmentation System (MSAS). India has launched its own SBAS program

named GPS and GEO Augmented Navigation (GAGAN) to cover the Indian subcontinent.

N10HD series module supports SBAS and RTCM, but only one mode can be applied at one time, and SBAS is the default feature, customers who want to apply RTCM in the design can contact Mobiletek sales for supporting

4.6 GNSS Antenna

The antenna is a critical item for successful GNSS reception in a weak signal environment. Proper choice of the antenna will ensure that satellites at all elevations can be seen, and therefore, accurate fix measurements are obtained.

User can choose an appropriate antenna for better performance, like active antenna or passive antenna.

4.6.1 Antenna Interface

The N10HD series receives L1 band signals from GPS and L1 band signals from Glonass or B1 band signals from BD2 satellites at a nominal frequency of 1558~1607MHz .The RF signal is connected to the GNSS_ANT pin. And the trace from the GNSS_ANT pin to antenna should be 50Ω controlled.

To suit the physical design of individual applications the RF interface pad can lead to two alternatives:

Recommended approach: solderable RF coaxial cable assembly antenna connector, such as

- HRS' U.FL-R-SMT connector or I-PEX's 20279-001E-01 RF connector.
- SMA connector.

4.6.2 Antenna Choice and RF Design Consideration

To obtain excellent GNSS reception performance, a good antenna will always be required. Proper choice and placement of the antenna will ensure that satellites at all elevations can be seen, and therefore, accurate fix measurements are obtained.

Compare the active antenna and passive antenna as follow:

Table 4-3 Antenna Specifications

Parameter	Specification	
Passive Antenna Recommendations	Frequency range	1558-1607MHz
	Polarization	RHCP & Linear
	Gain	>0dBi
Active Antenna Recommendations	Frequency range	1558-1607MHz
	Polarization	RHCP & Linear
	Noise Figure	<1.5dB
	Gain	>10dBi

Passive Antenna

Passive antenna contains only the radiating element, e.g. the ceramic patch, the helix structure, and chip antenna. Sometimes it also contains a passive matching network to match the electrical connection to 50Ω impedance.

The most common antenna type for GNSS applications is the patch antenna. Patch antennas are flat, generally have a ceramic and metal body and are mounted on a metal base plate.

Figure 4-3 shows a minimal setup for a GNSS receiver with N10HD series module.

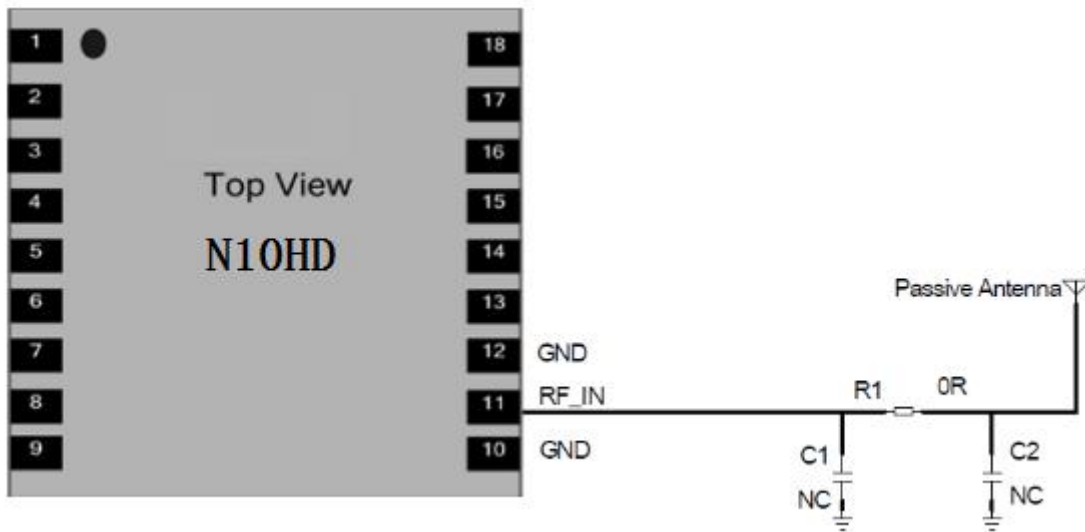

Figure 4-3 N10HD series passive antenna design

If the electromagnetic environment of module is very complicated, e.g. coexisted with GSM, UMTS, WLAN and Bluetooth, user can use a saw (IL<1.4dB) to increase the sensitivity. Please see Figure 4-4.

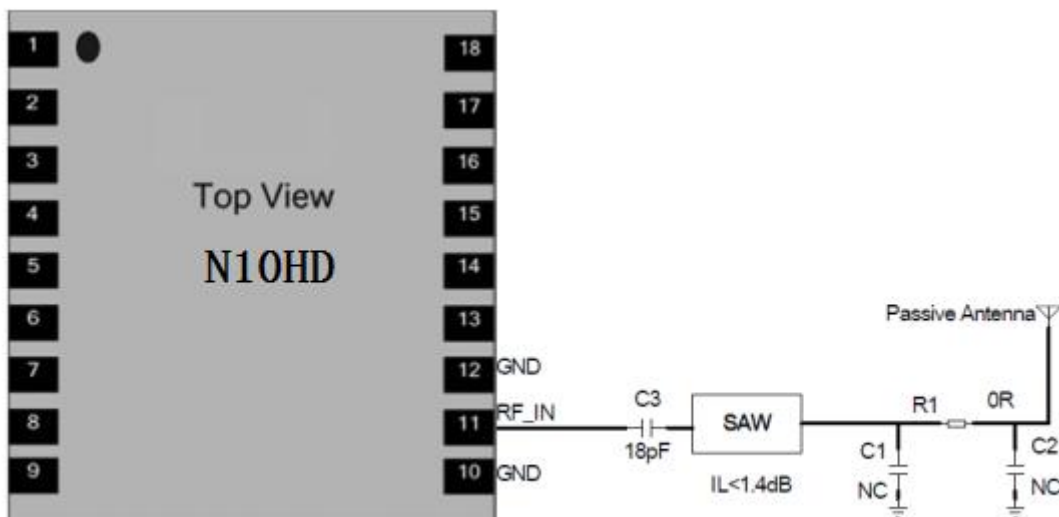

Figure 4-4 N10HD series passive antenna design (with external SAW)

If the passive antenna is far away from N10HD series, and the path loss is over 3dB, customers can use an external LNA to get a better performance. Please see Figure 4-5. This design is not recommended, it is recommended that the customer antenna close to the module placement.

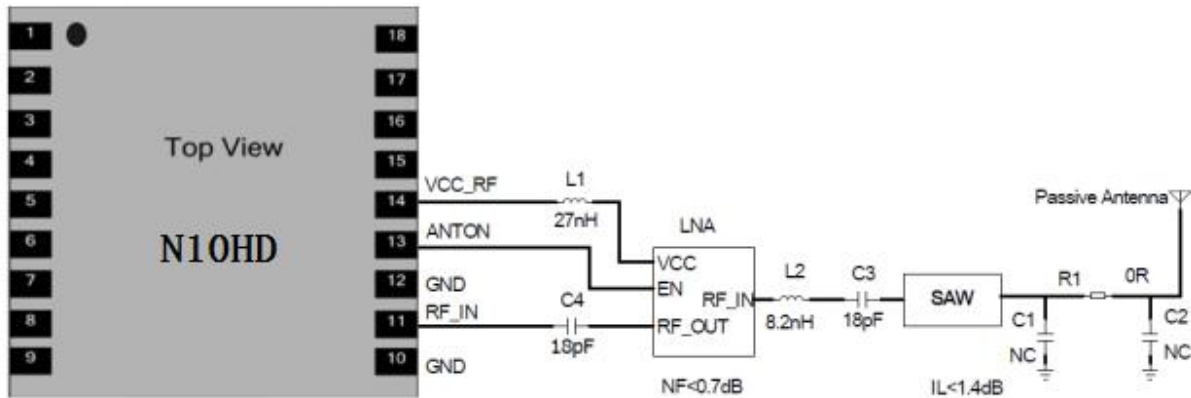

Figure 4-5 N10HD series passive antenna design(with external LNA and saw)

Active Antenna

Active antennas have an integrated Low-Noise Amplifier (LNA). Active antennas need a power supply that will contribute to GNSS system power consumption.

Usually, the supply voltage is fed to the antenna through the coaxial RF cable shown as Figure 10. The output voltage domain of PIN 14 is VCC. If the supply voltage domain of active antenna is VCC, PIN 14 VCC_RF can be connected to RF_IN as figure 4-6 shows. If the supply voltage domain of active antenna is not VCC, other power should be connected to RF_IN.

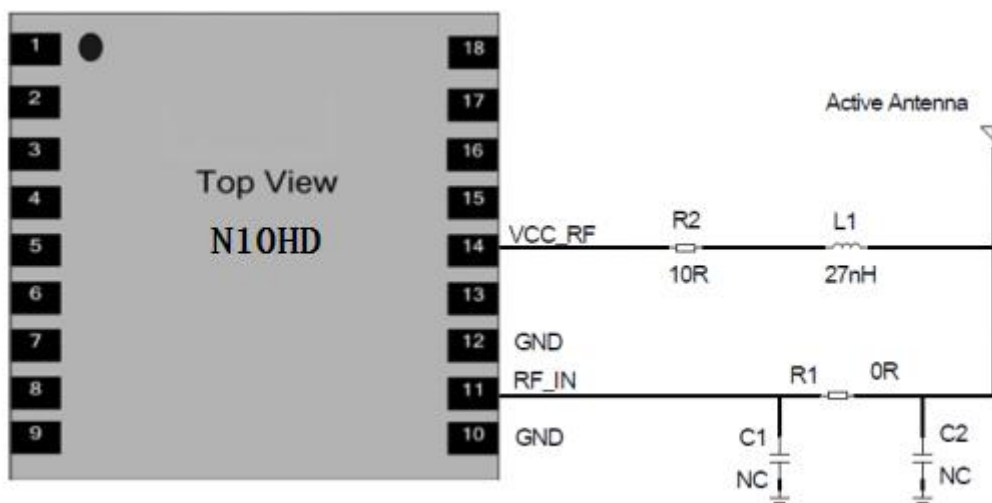

Figure 4-6 N10HD series active antenna design

User can use PIN13 ANTION to disable the power supply for external active antenna, which could

decrease the power consumption when N10HD series in sleep mode. Please see Figure 4-7.

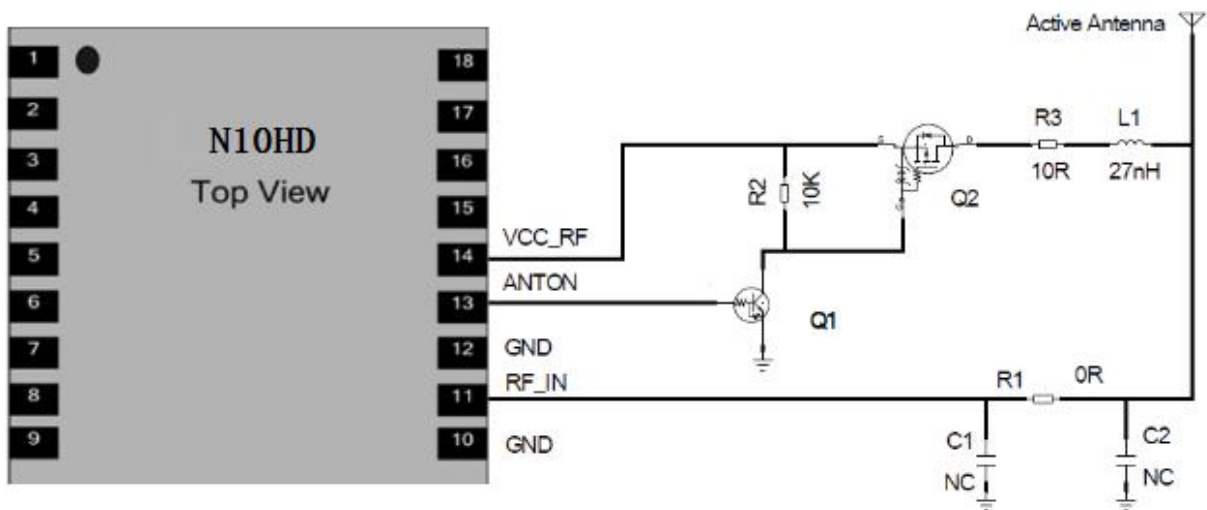

Figure 4-7 N10HD series active antenna design for low power consumption

If the customer's design is for automotive applications, then an active antenna can be used and located on C of the car in order to guarantee the best signal quality.

GNSS antenna choice should base on the designing product and other conditions. For detailed Antenna designing consideration, please refer to related antenna vendor's design recommendation. The antenna vendor will offer further technical support and tune their antenna characteristic to achieve successful GNSS reception performance depending on the customer's design.

5. Electrical Reliability and Radio Characteristics

5.1 Absolute Maximum Ratings

The absolute maximum ratings stated in Table 5-1 are stress ratings under non-operating conditions. Stresses beyond any of these limits will cause permanent damage to N10HD series.

Table 5-1 Absolute maximum rating

Parameter	Min	Max	Unit
VCC		3.6	V
VCC_RF		VCC	V
ANTON		+3.3	V
Input Power at GNSS_ANT		-12	dBm
VCC_BACKUP		3.6	V
I/O pin voltage		3.6	V
Storage temperature	-40	+85	°C
Operating Temperature	-40	+85	°C

5.2 Recommended Operating Conditions

Table 5-2 N10HD series operating conditions

Parameter	Symbol	Min	Type	Max	Unit
Operating temperature range		-40	+25	+85	°C
Main supply voltage	VCC	3.0	3.3	3.6	V
Backup battery voltage	VCC_BACKUP	2.0	3	3.6	V

Table 5-3 N10HD series standard IO feature

Parameter	Symbol	Min	Type	Max	Unit
Low level output voltage Test conditions IOL = 2mA and 4.0mA	VOL		0	0.40	V
High level output voltage Test conditions IOL = 2mA and 4.0mA	VOH	2.4	2.8		V
Low level input voltage	VIL	-0.3		0.8	V
High level input voltage	VIH	2.0		3.6	V
Input Pull-up resistance	RPU	40		190	KΩ
Input Pull-down resistance	RPD	40		190	KΩ
Input capacitance	CIN		5		pF
Load capacitance	Cload			8	pF
Tri-state leakage current	IOZ	-10		10	uA

5.3 Electro-Static Discharge

The GNSS engine is not protected against Electrostatic Discharge (ESD) in general. Therefore, it is subject to ESD handling precautions that typically apply to ESD sensitive components. Proper ESD handling and packaging procedures must be applied throughout the processing, handling and operation of any application using a N10HD series module. The ESD test results are shown in the following table.

Table 5-4 The ESD characteristics(Temperature:25°C,Humidity:45%)

Pin	Contact discharge	Air discharge
VCC	±5KV	±10KV
RF_ANT	±5KV	±10KV
VCC_BACKUP	±5KV	±10KV
ANTON	±5KV	±10KV

VCC_RF	±5KV	±10KV
GND	±5KV	±10KV
RXD0, TXD0	±4KV	±8KV
RESET	±4KV	±8KV
PPS	±4KV	±8KV

6. Manufacturing

6.1 Top and Bottom View of N10HD Series

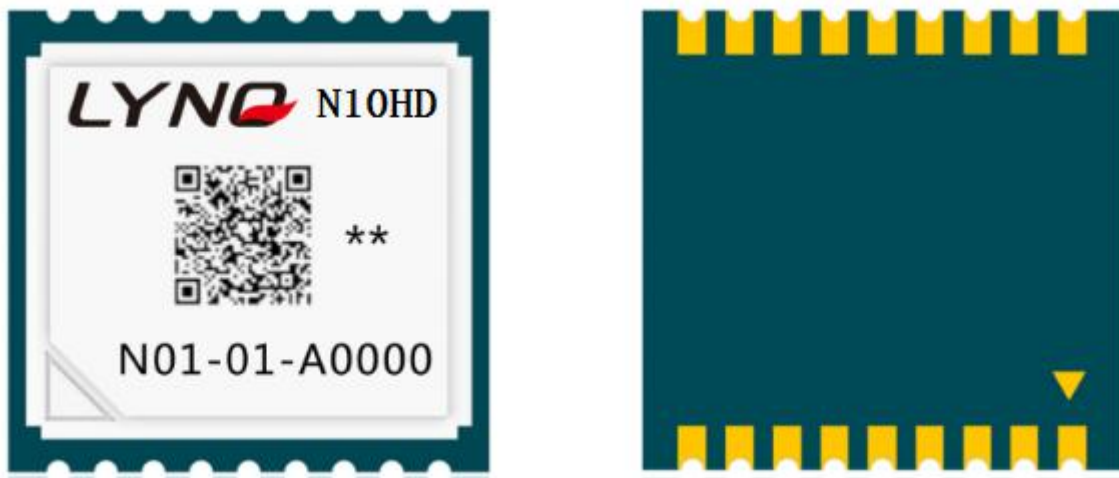

Figure 6-1 Top and Bottom View of N10HD series

6.2 Product labeling



Figure 6-2 Label of N10HD series

Table 6-1 Description of module label

Item	Description
A	Logo of company
B	QR code --- include hardware and software edition, date of manufacture, and baud rate, etc.
C	Pin1 mark
D	Module name
E	Satellite system and baud rate; Example B:GPS+BD2 G:GPS+Glonass,M:GPS+BD2,9:9600 ,1:115200 ;
F	PID number

6.3 Assembly and Soldering

The N10HD series module is intended for SMT assembly and soldering in a Pb-free reflow process on the top side of the PCB. Suggested solder paste stencil height is 150um minimum to ensure sufficient solder volume. If required paste mask pad openings can be increased to ensure proper soldering and solder wetting over pads.

The following figure is the Ramp-Soak-Spike Reflow Profile of N10HD series:

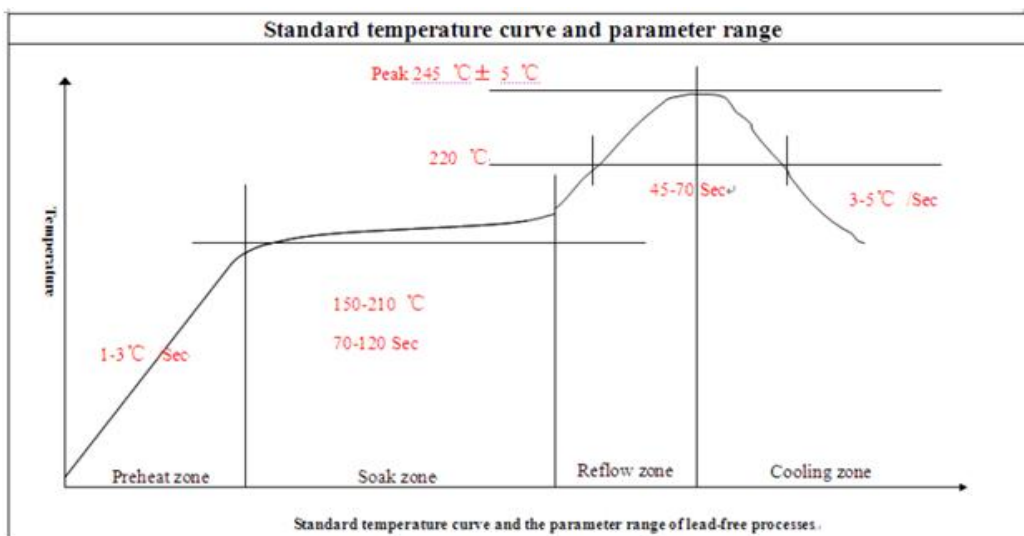

Figure 6-3 The Ramp-Soak-Spike reflow profile of N10HD series

N10HD series is moisture sensitive devices (MSD), appropriate MSD handling instruction and precautions are summarized in Chapter 6.3.

N10HD series modules are also Electrostatic Sensitive Devices (ESD), handling N10HD series modules without proper ESD protection may destroy or damage them permanently.

Avoid ultrasonic exposure due to internal crystal and SAW components.

6.4 Moisture Sensitivity

N10HD series module is moisture sensitive at MSL 3, dry packed according to IPC/JEDEC specification J-STD-020C. The calculated shelf life for dry packed SMD packages is a minimum of 6 months from the bag seal date, when stored in a non-condensing atmospheric environment of <math><40^{\circ}\text{C}/90\% \text{RH}</math>.

Table 6-2 lists floor life for different MSL levels in the IPC/JDEC specification:

Table 6-2 Moisture classification level and floor life

Level	Floor Life(out of bag)at factory ambient $\cong +30^{\circ}\text{C}/60\% \text{RH}$ or as stated
1	Unlimited at $\cong +30^{\circ}\text{C}/85\% \text{RH}$
2	1 year
2a	4 weeks
3	168 hours
4	72 hours
5	48 hours
5a	24 hours
6	Mandatory bake before use. After bake, module must be reflowed within the time limit specified on the label.

Factory floor life is 1 week for MSL 3, N10HD series must be processed and soldered within the time. If this time is exceeded, the devices need to be pre-baked before the reflow solder process.

Both encapsulate and substrate materials absorb moisture. IPC/JEDEC specification J-STD-020 must be observed to prevent cracking and delamination associated with the "popcorn" effect during reflow soldering. The popcorn effect can be described as miniature explosions of evaporating moisture. Baking before processing is required in the following case:

- Floor life or environmental requirements after opening the seal have been exceeded, e.g. exposure to excessive seasonal humidity.

Refer to Section 4 of IPC/JEDEC J-STD-033 for recommended baking procedures.

Notes: Oxidation Risk: Baking SMD packages may cause oxidation and/or inter metallic growth of the terminations, which if excessive can result in solder ability problems during board assembly. The temperature and time for baking SMD packages are therefore limited by solder ability considerations. The cumulative bake time at a temperature greater than 90°C and up to 125°C shall not exceed 96 hours.

6.5 ESD Handling Precautions

N10HD series modules are Electrostatic Sensitive Devices (ESD). Observe precautions for handling! Failure to observe these precautions can result in severe damage to the GNSS receiver!



GNSS receivers are Electrostatic Sensitive Devices (ESD) and require special precautions when handling. Particular care must be exercised when handling patch antennas, due to the risk of electrostatic charges. In addition to standard ESD safety practices, the following measures should be taken into account whenever handling the receiver:

Unless there is a galvanic coupling between the local GND (i.e. the work Table) and the PCB GND, then the first point of contact when handling the PCB shall always be between the local GND and PCB GND.

Before mounting an antenna patch, connect ground of the device.

When handling the RF pin, do not come into contact with any charged capacitors and be careful when contacting materials that can develop charges (e.g. patch antenna ~10pF, coax cable ~50-80pF/m, soldering iron)

To prevent electrostatic discharge through the RF input, do not touch the mounted patch antenna.

When soldering RF connectors and patch antennas to the receiver's RF pin, the user must make sure to use an ESD safe soldering iron (tip).

6.6 Shipment

N10HD series is designed and packaged to be processed in an automatic assembly line, and it is now packaged tray and reel.

7. Reference Design

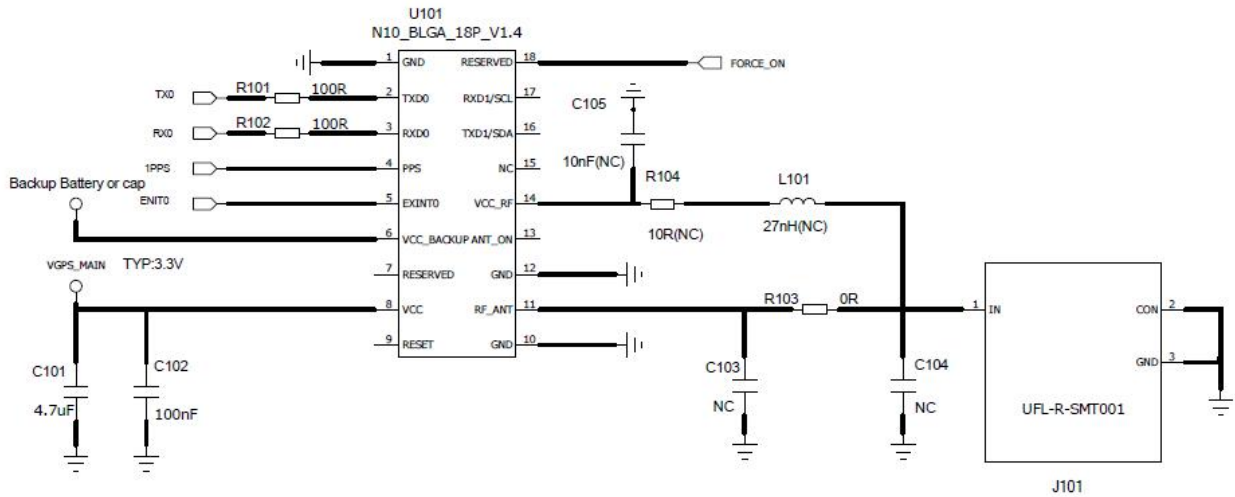

Figure 7-1 Application schematics

8. Safety Information

For the reasonable usage of the module, please comply with all these safety notices of this page. The product manufacturers should send followed safety information to user, operator or product's spec.



The devices using the module may disturb some electronic equipment. Put the module away from the phone, TV, radio and automation equipment to avoid the module and the equipment to interfere with each other.



Shut down the mobile device or change to flying mode before boarding. The Using of wireless appliances in an aircraft is forbidden to avoid the interference, or else cause to unsafe flying, even violate the law.



In hospital or health care center, switch off the mobile devices. RF interference may damage the medical devices, like hearing-aid, cochlear implant and heart pacemaker etc.



Mobile devices can't guarantee to connect in all conditions, like no fee or with an invalid SIM card. When you need emergent help, please remember using emergency calls and make sure your device power on in an area with well signal.



Put the module away from inflammable gases. Switch off the mobile device when close to gas station, oil depot, chemical plant etc.



The module is not water proof. Please don't use the module in the area with high humidity like bathroom, which will decelerate the physical performance, insulation resistance and mechanical strength.



Non-professionals can't teardown the module which will damage it. Refer to the specification or communicate the related staffs to repair and maintain it.



Please switch on the module before cleaning. The staffs should be equipped with anti-ESD clothing and gloves.

The users and product manufacturers should abide by the national law of wireless modules and devices. If not, Mobiletek will not respond the related damages.

Appendix

Related Documents

SN	Document name	Remark
[1]	LYNQ_GNSS_SDK_Commands_Manual	
[2]	EPO-II Format Protocol Customer	

Terms and Abbreviations

Abbreviation	Description
A-GPS	Assisted Global Positioning System
CMOS	Complementary Metal Oxide Semiconductor
CEP	Circular Error Probable
DGPS	Difference Global Positioning System
EEPROM	Electrically Erasable Programmable Read Only Memory
EPO	Extended Prediction Orbit
ESD	Electrostatic Sensitive Devices
EASY	Embedded Assist System
EGNOS	European Geostationary Navigation Overlay Service
GPS	Global Positioning System
GAGAN	The GPS Aided Geo Augmented Navigation
I/O	Input / Output
IC	Integrated Circuit
Inorm	Normal Current
Imax	Maximum Load Current

kbps	Kilo bits per second
MSL	moisture sensitive level
MSAS	Multi-Functional Satellite Augmentation System
NMEA	National Marine Electronics Association
PRN	Pseudo Random Noise Code
QZSS	Quasi-Zenith Satellites System
SBAS	Satellite Based Augmentation Systems
WAAS	Wide Area Augmentation System